

Creative Crown™

Product Information Sheet

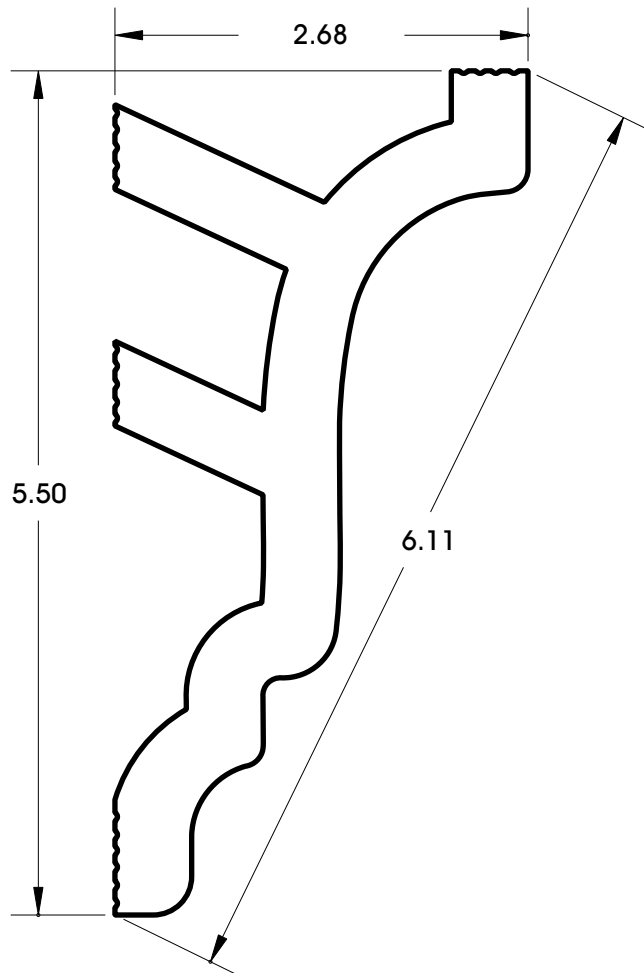

Not to scale

Part# 5.5.2

Creative Crown moldings are made of high density, white, smooth molded polystyrene. Our high density manufacturing process achieves a totally smooth surface. (no bead look) The flat back molding design is the first and only world wide. (patent pending design). Our moldings can be cut in most any positions in most miter saws.

Creative Crown moldings are 100% American made and NAFTA approved. Our crown moldings have a minimum density of 4.0 lbs.

It can be installed on almost any surface such as: sheetrock, wood, gypsum, brick, concrete, stucco, glass, metal etc. No nails, screws, clips or fasteners are required for installation.

If painters caulk will adhere to the surface, Creative Crown moldings can be installed.

The molding surface only requires one coat of water based latex paint.

“Use water based paints only”

All moldings come in 95.5" lengths.

Application Compliance: Class A Fire Rated

EPS foams manufactured from Styropor BFL comply with surface burning characteristics (ASTM E-84) and physical property (ASTM C- 578) requirements of U.S. model building codes. National Evaluation Service report NER-479 and ICBO Evaluation Service report ER 4301 contain specific code compliance criteria for Styropor BFL. EPS foams manufactured from Styropor BFL meet UL 94 classification requirements and have obtained an HF-1 rating as described in UL listing E54675.

Technical specifications for the BFL products are listed in Table 2.

Creative Crown™

1265 West Kilpatrick Street Cleburne, Texas 76033

www.creativecrown.com

6-16-2014